



basic education
 Department:
Basic Education
REPUBLIC OF SOUTH AFRICA

**SENIOR CERTIFICATE EXAMINATION/
 NATIONAL SENIOR CERTIFICATE EXAMINATION**

ENGINEERING GRAPHICS AND DESIGN P2
2022

MARKS: 100

TIME: 3 hours



This question paper consists of 6 pages.

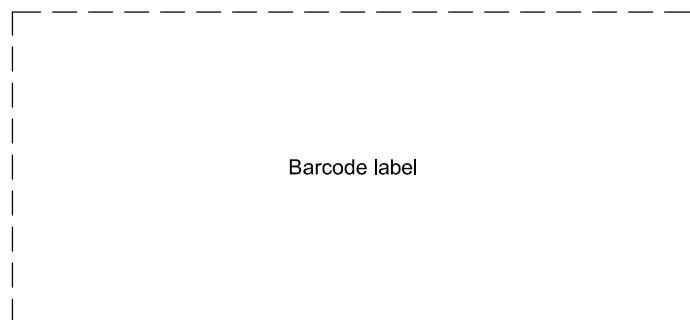

Barcode label

INSTRUCTIONS AND INFORMATION

1. This question paper consists of FOUR questions.
2. Answer ALL the questions.
3. ALL drawings are in third-angle orthographic projection, unless otherwise stated.
4. ALL drawings must be prepared using pencil and instruments, unless otherwise stated.
5. ALL answers must be drawn accurately and neatly.
6. ALL the questions must be answered on the QUESTION PAPER, as instructed.
7. Do not fold any of the pages of the question paper in half.
8. ALL the pages, irrespective of whether the question was attempted or not, must be re-stapled in numerical sequence in the TOP LEFT-HAND CORNER ONLY.
9. Time management is essential in order to complete all the questions.
10. Print your examination number in the block provided on every page.
11. Any details or dimensions not given must be assumed in good proportion.

FOR OFFICIAL USE ONLY															
QUESTION	MARKS OBTAINED			$\frac{1}{2}$	SIGN	MODERATED			$\frac{1}{2}$	SIGN	RE-MARKING			$\frac{1}{2}$	SIGN
1															
2															
3															
4															
TOTAL															
	2	0	0			2	0	0			2	0	0		

FINAL CONVERTED MARK	CHECKED BY
100	

COMPLETE THE FOLLOWING:
CENTRE NUMBER
CENTRE NUMBER
EXAMINATION NUMBER
EXAMINATION NUMBER

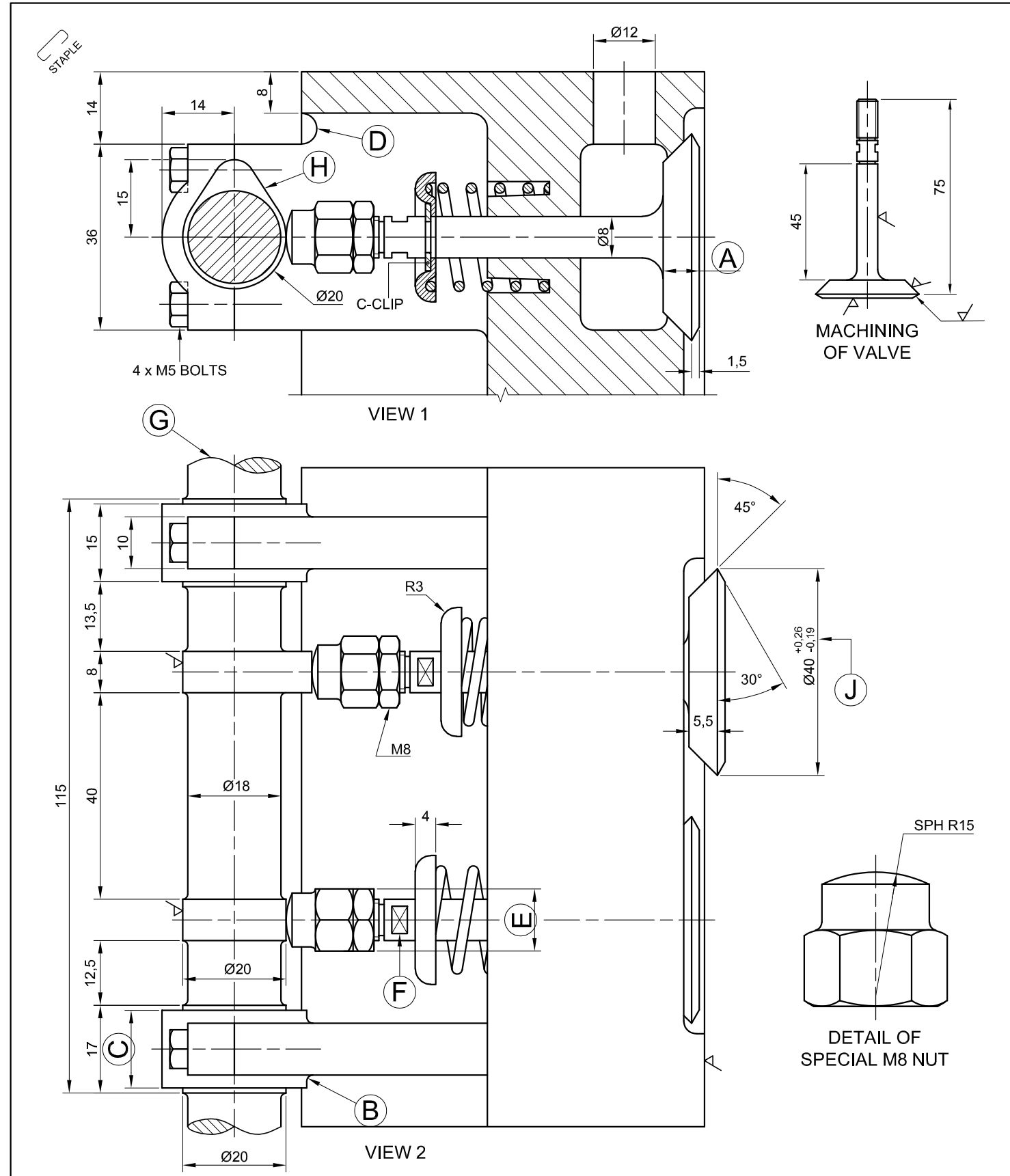

QUESTION 1: ANALYTICAL (MECHANICAL)

Given:

Two sectional views of a cylinder head sub-assembly, a detailed view of a valve, a title block and a table of questions. The drawing is not presented to the indicated scale.

Instructions:

Complete the table below by neatly answering the questions which refer to the accompanying drawing, the title block and mechanical content. [30]

QUESTIONS		ANSWERS	
1	What is the name of the manufacturing company?	1	
2	Who approved the drawing?	1	
3	How many sets of drawings are there for this sub-assembly?	1	
4	On what date was the drawing prepared?	1	
5	Referring to the projection symbol, what is the projection system used?	1	
6	Which drawing program was used to prepare the drawing?	1	
7	What size bolts are required for the sub-assembly?	1	
8	How many coil springs are there in this sub-assembly?	1	
9	Determine the complete dimensions at: A: B: C: D: E:	5	
10	What is the radius of the spherical cap?	1	
11	What does the convention at F indicate?	1	
12	What does the convention at G indicate?	1	
13	What machining method must be used on the machined surfaces?	1	
14	With reference to the tolerance, determine the minimum dimension at J.	1	
15	With reference to the CAM at H, determine the displacement of the follower.	1	
16	If VIEW 1 is the SECTIONAL FRONT VIEW, what is VIEW 2 called?	1	
17	How many surfaces on this sub-assembly require machining?	1	
18	Insert the cutting plane for VIEW 1 on VIEW 2 and label it A-A.	3 ½	
19	In the space below (ANSWER 19), draw, in neat freehand, the complete SANS 10111 conventional representation of a COIL SPRING.	3	
20	On the drawing below (ANSWER 20), draw, in neat freehand, the complete SANS 10111 conventional representation for DIAMOND KNURLING.	2 ½	
TOTAL		30	

FILE NAME: JBVW101	DRAWING No. CAM12	DRAWING SET: 1 OF 4	MC ENGINEERING WORKS www.cheads.co.za CELL: 090 714 4322 44 DIESEL STREET KIMBERLEY 0220	GRINDING 3,2 0,55
DRAWING PROGRAM: AUTOCAD 2021		SCALE 1 : 1	ALL UNSPECIFIED RADII ARE R2.	
DRAWN:	VUSI	DATE: 02/04/2021		
CHECKED:	TARYN	DATE: 03/05/2021		
APPROVED:	GERALD	DATE: 02/07/2021		
			TITLE	
			CYLINDER HEAD SUB-ASSEMBLY	

ANSWER 19

COMPLETE CONVENTIONAL REPRESENTATION OF A COIL SPRING

ANSWER 20

CONVENTIONAL REPRESENTATION OF DIAMOND KNURLING

EXAMINATION NUMBER

EXAMINATION NUMBER



O+

QUESTION 2: LOCI

NOTE: Answer QUESTIONS 2.1 and 2.2.

2.1 MECHANISM

Given:

- A schematic drawing of a mechanism consisting of crank OA, connecting rod BC and swivel guide E
- The position of centre point O on the drawing sheet

Specifications:

- The positions of centre point O and swivel guide E are fixed.
- Connecting rod BC is pin-jointed to crank OA at A.

Motion:

Crank OA oscillates through 180° on centre point O as connecting rod BC slides freely through swivel guide E.

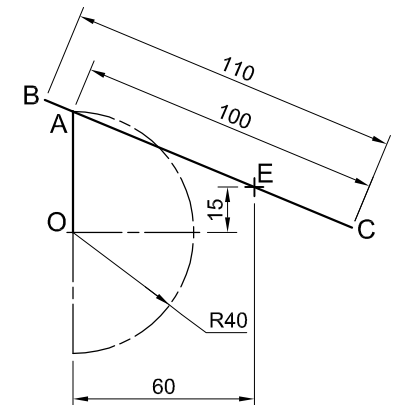

Instructions:

- Draw, to scale 1 : 1, the given schematic drawing of the mechanism.
- Trace the loci generated by point B and by point C for ONE oscillation of crank OA.
- Show ALL construction. **[20]**

ASSESSMENT CRITERIA 2.1

1	GIVEN	4		
2	CONSTRUCTION	2		
3	POINTS + CURVE	14		
SUBTOTAL		20		

2.2 CAM

Motion:

A cam, starting at its **maximum** displacement and rotating at constant velocity, imparts the following motion to a follower:

- It descends 10 mm with uniform motion over the first 60°.
- It descends a further 80 mm to the **minimum** displacement with simple harmonic motion over the next 90°.
- There is a dwell period for 30°.
- It rises 60 mm with uniform acceleration and retardation over the next 90°.
- There is a dwell period for 30°.
- It returns to its original position with uniform motion over the rest of the rotation.

Instructions:

- Draw, to a displacement scale of 1 : 1 and a rotational scale of 144 mm = 360°, the complete displacement graph for the required motion.
- Label the displacement graph and indicate the rotational scale.
- Show ALL construction. **[18]**



ASSESSMENT CRITERIA 2.2

1	CONSTRUCTION	6		
2	POINTS + CURVE	11		
3	LABELS	1		
PENALTIES (-)				
2.2 SUBTOTAL		18		
2.1 SUBTOTAL		20		
TOTAL		38		

EXAMINATION NUMBER

EXAMINATION NUMBER

3



QUESTION 3: ISOMETRIC DRAWING

Given:

- The front view, top view and left view of a gauge
- The position of point P on the drawing sheet

Instructions:

Using scale 1 : 1, convert the orthographic views of the gauge into an isometric drawing.

- Use P as the starting point for the drawing.
- Show ALL construction.
- NO hidden detail is required. **[39]**

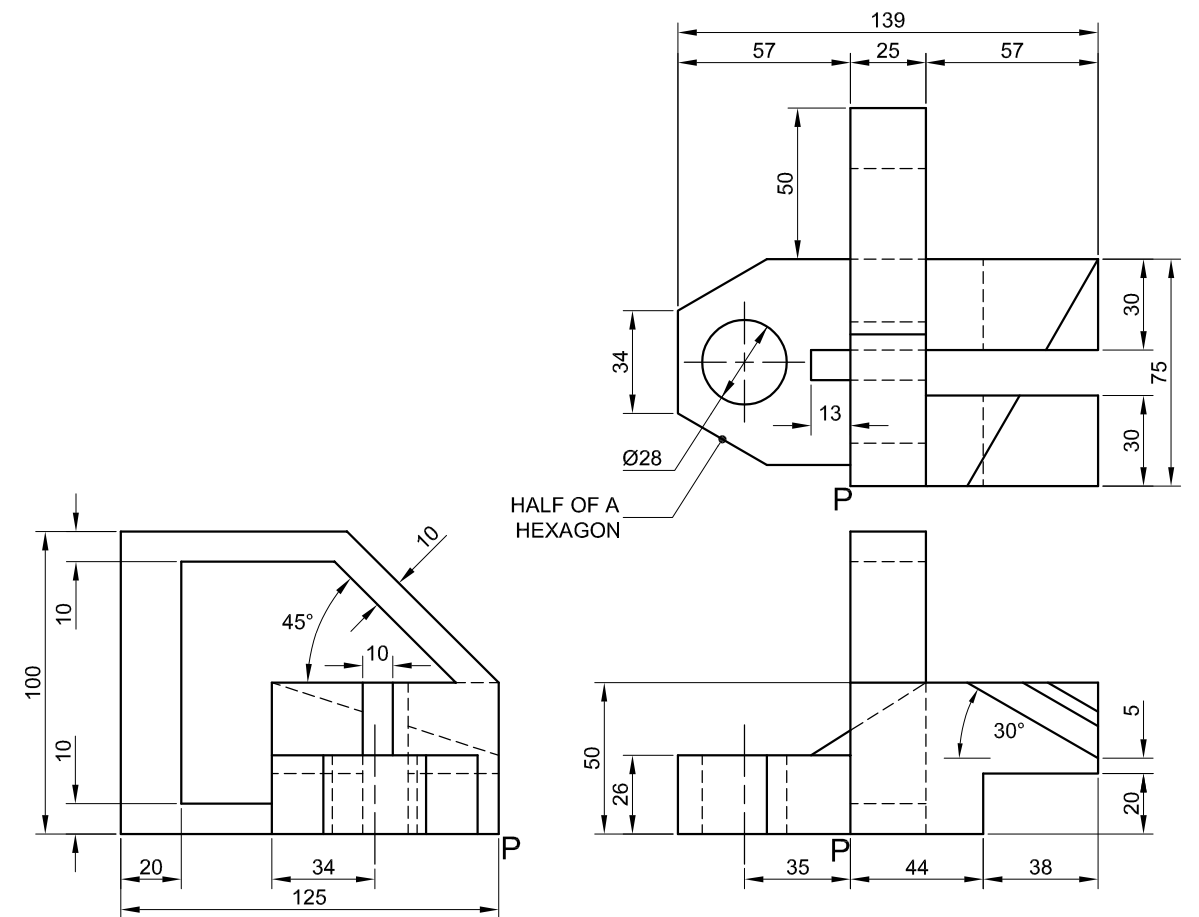

P

ASSESSMENT CRITERIA				
1	PLACING + AUX VIEWS	4		
2	LEFT PART	17		
3	MIDDLE PART	7 1/2		
4	RIGHT PART	5		
5	CIRCLE + CENTRE LINES + CONSTR'	5 1/2		
PENALTIES (-)				
TOTAL		39		
EXAMINATION NUMBER				
EXAMINATION NUMBER				4



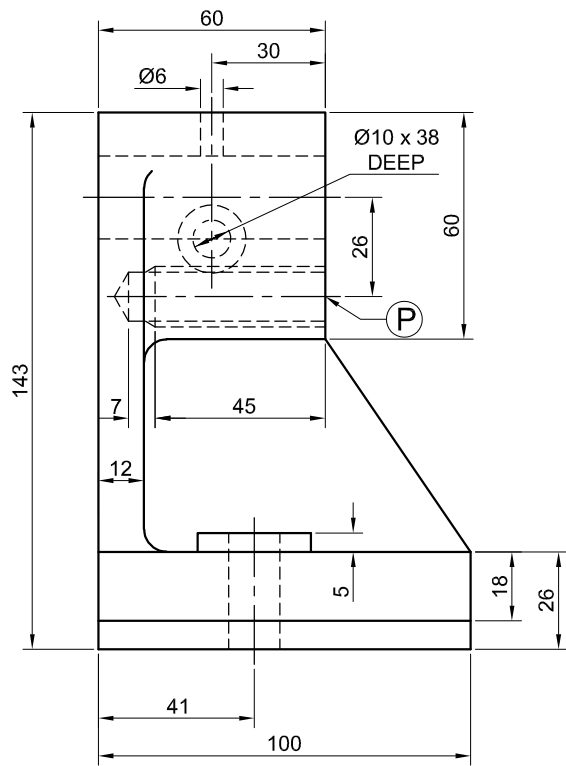

TAILSTOCK [1]

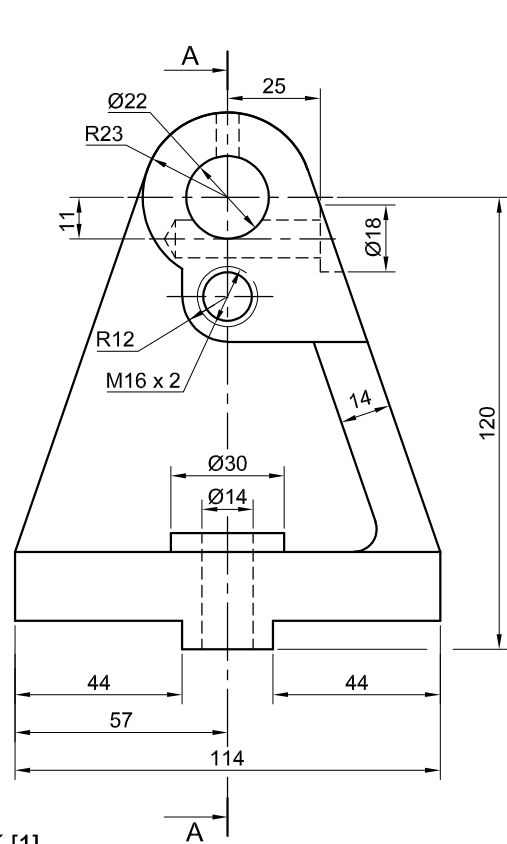

ADJUSTING HAND WHEEL [4]

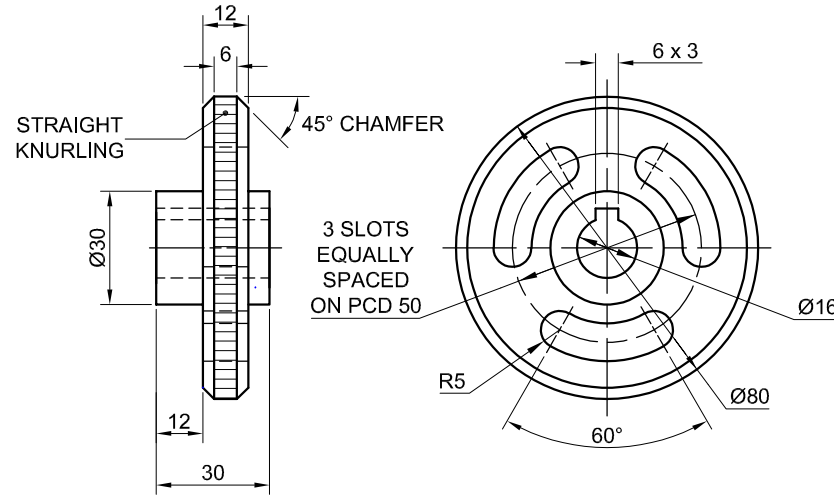

KEY [5]

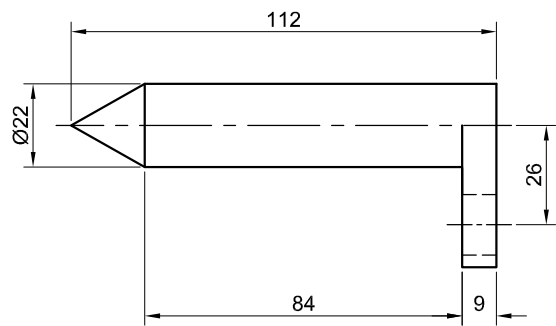

DEAD CENTRE [2]

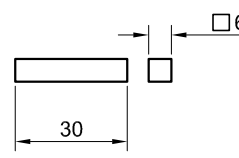

WASHER [6]

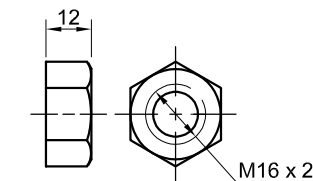

M16 NUT [7]

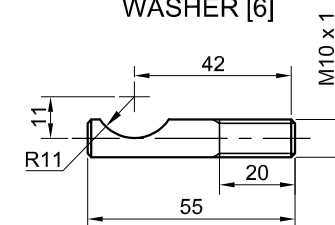

M10 LOCKING STUD [8]

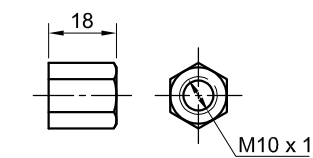

M10 LOCKING NUT [9]

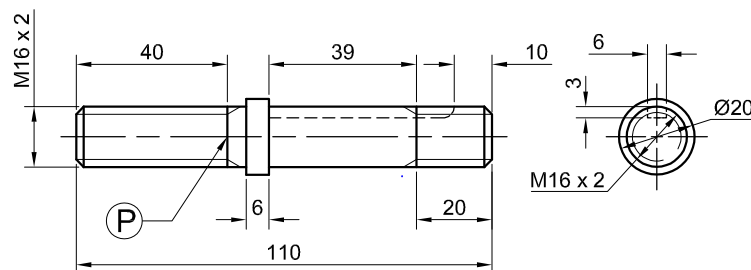

ADJUSTING STUD [3]

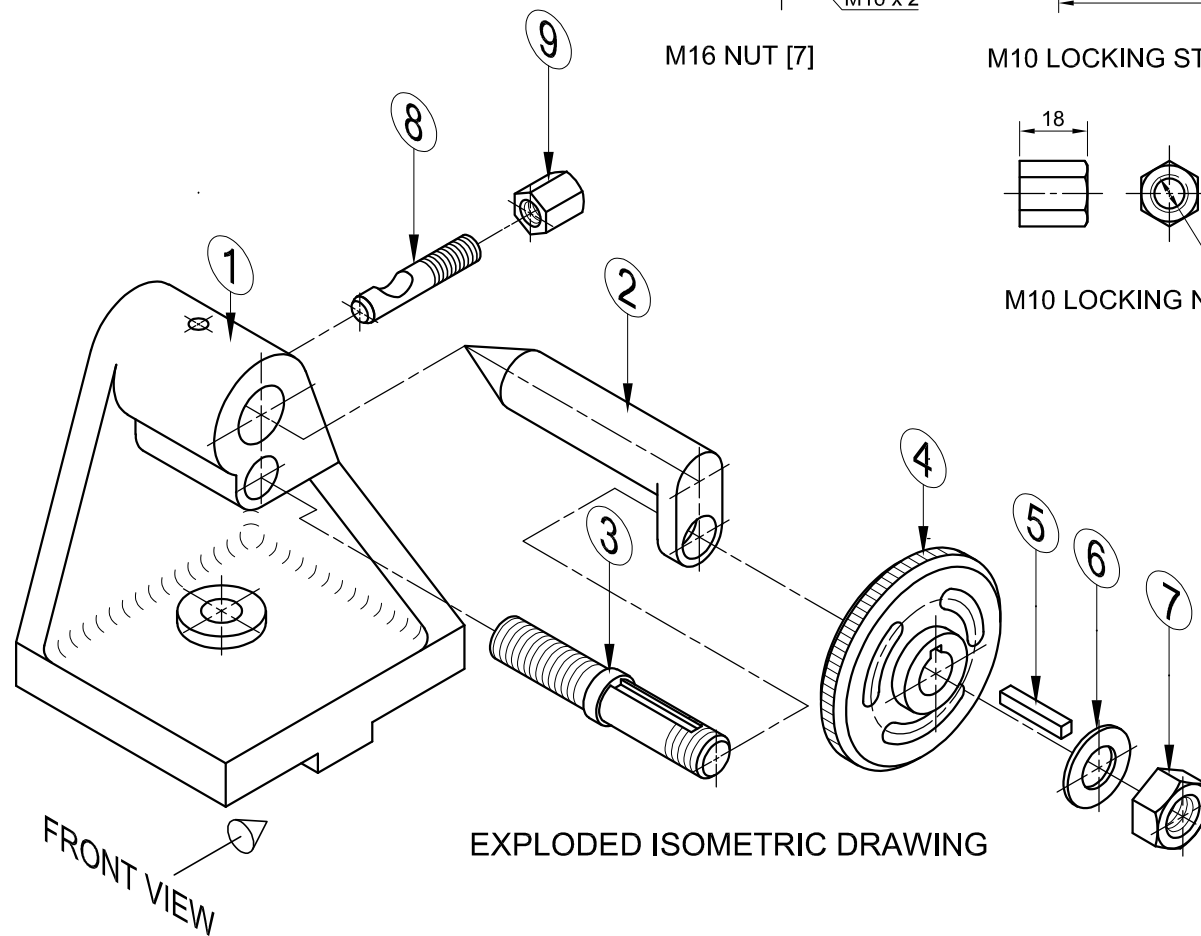

EXPLODED ISOMETRIC DRAWING

QUESTION 4: MECHANICAL ASSEMBLY

Given:

- The exploded isometric drawing of the parts of a tailstock assembly, showing the position of each part relative to all the others
- Orthographic views of each of the parts of the tailstock assembly

Instructions:

- Answer this question on page 6.
- Draw, to scale 1 : 1 and in third-angle orthographic projection, the following views of the assembled parts of the tailstock assembly:
 - 4.1 **A sectional front view** on cutting plane A-A, as seen from the direction of the arrow on the exploded isometric drawing. The cutting plane is shown on the right view of the tailstock (part 1).
 - 4.2 **The right view**

NOTE:

- Planning is essential.
- The drawing must comply with the SANS 10111 guidelines.
- Align point P on the adjusting stud (part 3) with point P on the tailstock (part 1).
- Show THREE faces of the M16 nut (part 7) in the front view and TWO faces of the M10 locking nut (part 9) in the right view.
- NO hidden detail is required.
- Add cutting plane A-A.

[93]



PARTS LIST			
PARTS	QUANTITY	MATERIAL	
1	TAILSTOCK	1	CAST IRON
2	DEAD CENTRE	1	ALLOY STEEL
3	ADJUSTING STUD	1	MILD STEEL
4	ADJUSTING HAND WHEEL	1	CAST STEEL
5	KEY	1	MILD STEEL
6	WASHER	1	MILD STEEL
7	M16 NUT	1	MILD STEEL
8	M10 LOCKING STUD	1	MILD STEEL
9	M10 LOCKING NUT	1	MILD STEEL

TURNIT
ENGINEERING CC

11 SALAH ROAD
MANE
www.turnit.co.za

TAILSTOCK ASSEMBLY

ALL DIMENSIONS ARE IN MILLIMETRES.
ALL UNSPECIFIED RADII ARE 6 mm.

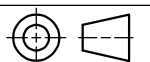

5



FOR OFFICIAL USE ONLY	
INCORRECT ORTHOGRAPHIC PROJECTION	
INCORRECT OVERALL SCALE	
INCORRECT HATCHING	
PARTS NOT ASSEMBLED	
TOTAL PENALTIES (-)	



ASSESSMENT CRITERIA					
RIGHT VIEW					
		POSSIBLE	OBTAINED	SIGN	MODERATED
1	TAILSTOCK	8 1/2			
2	ADJUSTING WHEEL + DEAD CENTRE	8			
3	M16 NUT + WASHER + LOCKING NUT	6 1/2			
4	ADJUSTING STUD	1 1/2			
SUBTOTAL		24 1/2			
SECTIONAL FRONT VIEW					
1	TAILSTOCK	14			
2	DEAD CENTRE	7			
3	ADJUSTING WHEEL	9			
4	ADJUSTING STUD	16 1/2			
5	M16 NUT + WASHER + M10 LOCKING BOLT	6 1/2			
6	KEY	1 1/2			
SUBTOTAL		54 1/2			
GENERAL					
1	CENTRE LINES	4			
2	CUTTING PLANE	3			
3	ASSEMBLY	7			
SUBTOTAL		14			
TOTAL		93			
PENALTIES (-)					
GRAND TOTAL					
EXAMINATION NUMBER					
EXAMINATION NUMBER					
					6