



Province of the
EASTERN CAPE
EDUCATION

**NATIONAL
SENIOR CERTIFICATE**

GRADE 11

NOVEMBER 2019

**ELECTRICAL TECHNOLOGY:
DIGITAL ELECTRONICS**

MARKS: 200

TIME: 3 hours



This question paper consists of 12 pages, including a formula sheet.

INSTRUCTIONS AND INFORMATION

1. Answer ALL the questions.
2. Sketches and diagrams must be large, neat and fully labelled.
3. ALL calculations must be shown, and correctly rounded off to TWO decimal places.
4. Show units for ALL answers of calculations.
5. Answers must be numbered correctly according to the numbering system used in this question paper.
6. Non-programmable calculators may be used.
7. A formula sheet is provided at the end of the question paper.
8. Write neatly and legibly.

QUESTION 1: OCCUPATIONAL HEALTH AND SAFETY

- 1.1 Describe the term *regulation* with respect to the Occupational Health and Safety Act (OHS). (2)
- 1.2 Name TWO unsafe acts that may result in an injury in an electrical workshop. (2)
- 1.3 Explain the term *ergonomics*. (2)
- [6]**

QUESTION 2: TOOLS AND MEASURING INSTRUMENTS

- 2.1 Explain TWO purposes of an oscilloscope. (2)
- 2.2 Describe the purpose of a jigsaw. (2)
- 2.3 State the maximum distance between the tool rest and the grinding wheel. (1)
- 2.4 Give ONE advantage of using a power factor meter. (1)
- [6]**

QUESTION 3: LOGIC

3.1 Refer to FIGURE 3.1 below and answer the questions that follow.

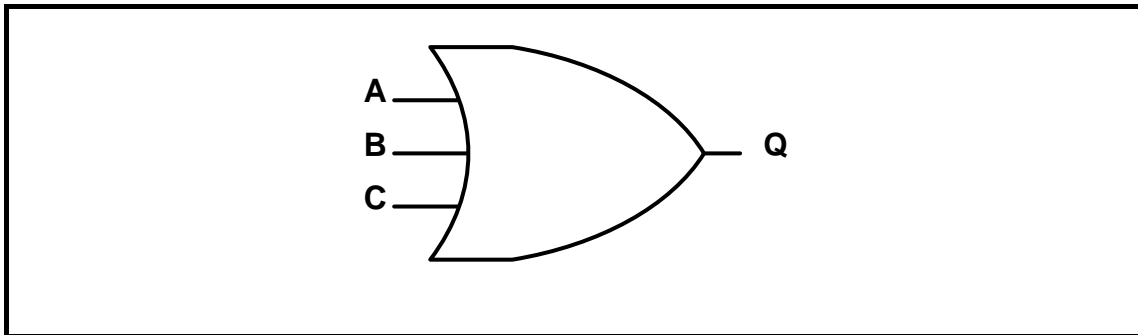

FIGURE 3.1

- 3.1.1 Identify the logic symbol in FIGURE 3.1. (1)
- 3.1.2 Write down the Boolean expression for the logic symbol in FIGURE 3.1 (2)
- 3.2 Draw the truth table for a TWO input Exclusive NOR (XNOR) gate. (4)
- 3.3 Draw the logic symbol for a TWO input Exclusive OR (XOR) gate. (1)
- 3.4 Refer to FIGURE 3.4 below and answer the following questions.

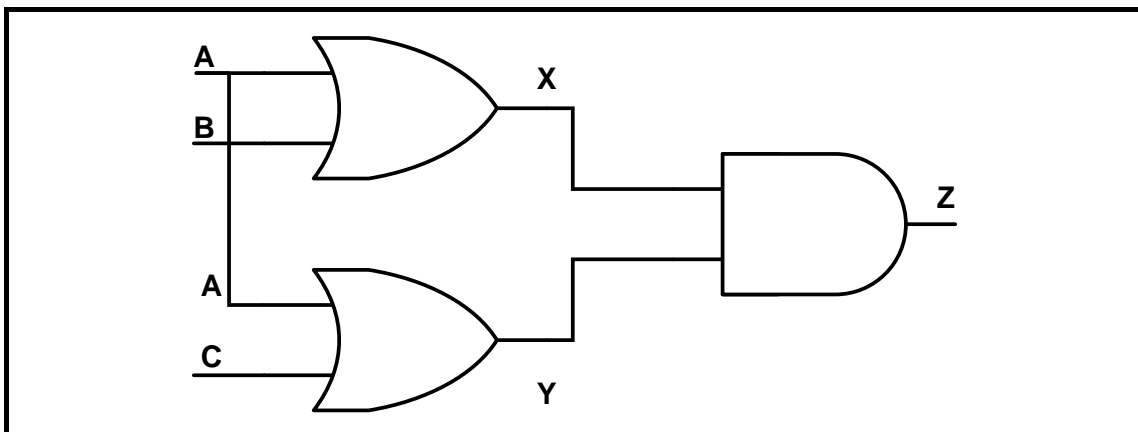
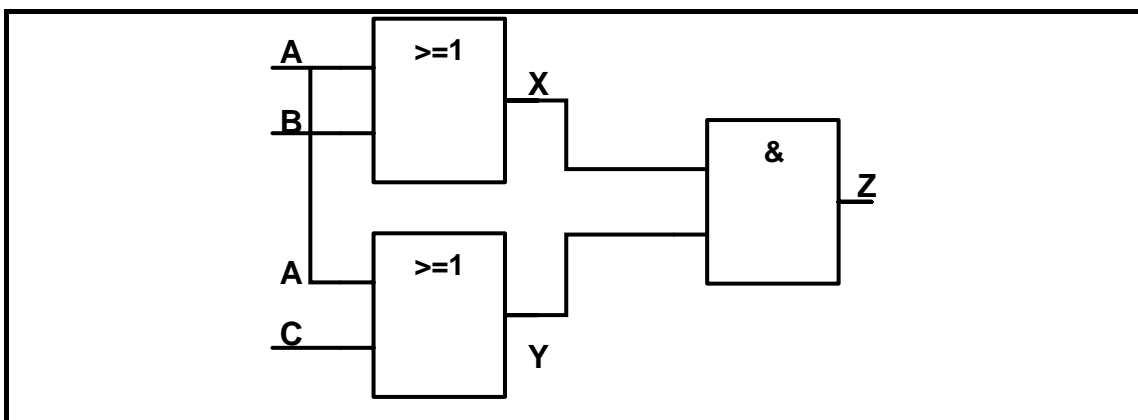
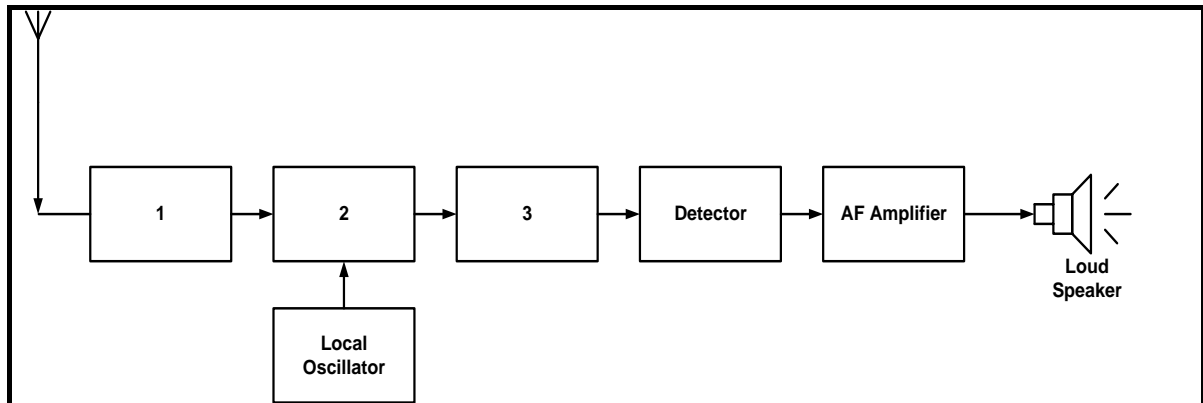

FIGURE 3.4

- 3.4.1 Give the Boolean expression at POINT X. (2)
- 3.4.2 Give the Boolean expression at POINT Y. (2)
- 3.4.3 Give the Boolean expression at POINT Z. (3)
- 3.5 Using Boolean algebra simplify the expression below:
- $$X = A.B.C + \bar{A} + A.\bar{B}.C \quad (5)$$
- 3.6 Draw a fully labelled circuit diagram of a Half Adder using an AND gate and a XOR gate. (4)
- 3.7 A system has two inputs and two outputs. The outputs are reflected by a RED and a GREEN indication light. The conditions for the indication lights to be on are as follow:
- RED: Will only be on when NONE or ONE of the inputs are on.
GREEN: Will only be on when BOTH inputs are on.
- Answer the following questions:
- 3.7.1 Draw a truth table for the conditions when the RED indicator will be on. (4)
- 3.7.2 Design a logic circuit for the conditions when the RED indicator is on by making use of NAND gates ONLY. (6)
- 3.8 Draw a fully labelled circuit diagram of a Resistor Transistor Logic (RTL) AND Gate. (6)
- [40]**

QUESTION 4: COMMUNICATION SYSTEMS

- 4.1 Define the term *modulation* when used in radio transmission. (2)
- 4.2 Give TWO advantages of a continuous wave (CW) transmission. (2)
- 4.3 Explain the operation of a regenerative receiver. (4)
- 4.4 Refer to FIGURE 4.4 below and label blocks 1–3. (3)



- 4.5 Draw a block diagram of a single sideband transmitter. (5)
- 4.6 Describe the TWO applications of a single sideband transmitter (SSB). (2)
- 4.7 List THREE stages of a phase locked loop. (3)
- 4.8 Describe the purpose of a continuous wave transmitter (CW). (3)

[24]

QUESTION 5: RLC CIRCUITS

- 5.1 Define the term *vector*. (1)
- 5.2 Explain what will happen to the following reactance if the frequency of the supply voltage decreases:
- 5.2.1 Capacitive reactance (1)
- 5.2.2 Inductive reactance (1)
- 5.3 Refer to the circuit diagram FIGURE 5.3 and answer the questions that follow.

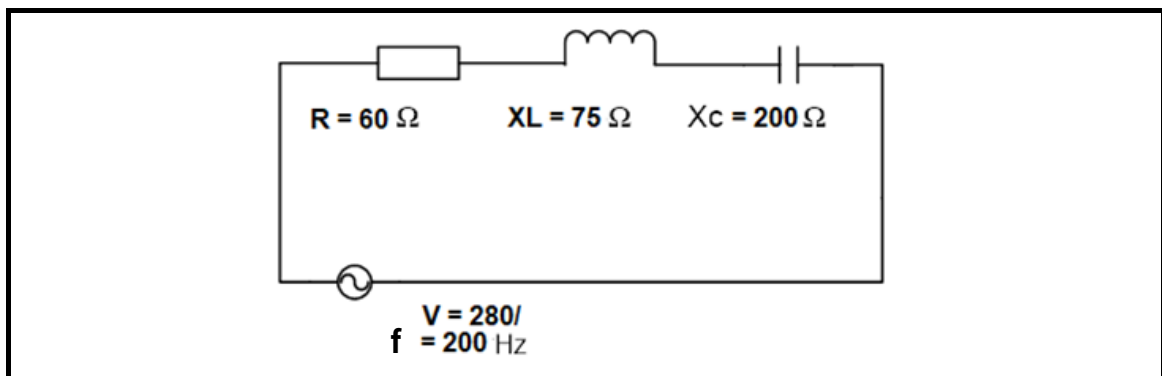
**FIGURE 5.3 SERIES RLC CIRCUIT**

Given: $R = 60 \Omega$
 $X_L = 175 \Omega$
 $X_C = 200 \Omega$
 $V = 280 \text{ V}$
 $f = 200 \text{ Hz}$

Calculate:

- 5.3.1 The impedance of the circuit (3)
- 5.3.2 The supply current (3)
- 5.3.3 The true power (3)
- 5.3.4 The reactive power (3)
- 5.3.5 Apparent power (3)
- 5.4 A series circuit consist of a 50Ω resistor, current of $0,2 \text{ A}$, an inductance of 40 mH and a capacitor of $5 \mu\text{F}$ connected to sinusoidal supply voltage with a constant output of 10 V .

Calculate:

- 5.4.1 Resonant frequency (3)
- 5.4.2 The inductive reactance at resonance (3)

[24]

QUESTION 6: WAVEFORMS

- 6.1 Name THREE types of waveforms. (3)
- 6.2 With reference to waveforms, define the following terms:
- 6.2.1 Instantaneous Value (3)
 - 6.2.2 Rise time (3)
 - 6.2.3 Average Value (3)
 - 6.2.4 Root Mean Square Value (3)
 - 6.2.5 Form Factor (2)
- 6.3 A sinewave has a maximum Voltage Value of 12 V and a cycle time of 20 ms. Calculate the frequency of the waveform. (3)
- 6.4 With reference to an INTEGRATOR circuit, explain why a square wave input will produce a triangular wave output. (3)
- 6.5 Explain THREE reasons for using diode clipping circuits. (3)

[26]

QUESTION 7: POWER SUPPLIES

- 7.1 With reference to power supplies, explain the function of the following:
- 7.1.1 Transformer (2)
 - 7.1.2 Rectifier (2)
 - 7.1.3 Regulator (2)
- 7.2 Name TWO applications of a Switch Mode Power Supply. (2)
- 7.3 Switch Mode Power Supplies rely on a Pulse Width Modulation stage to control the average value of the output voltage.
- Explain how this control is achieved. (4)
- [12]**

QUESTION 8: SEMI-CONDUCTOR DEVICES

- 8.1 Define the following terms:
- 8.1.1 Doping (1)
 - 8.1.2 Extrinsic material (2)
 - 8.1.3 N-TYPE semiconductor (2)
- 8.2 Explain the term “minority charge carrier” with reference to a N-Type material. (2)
- 8.3 Explain how a depletion region is formed in a diode. (3)
- 8.4 Name the FOUR stages of operation of a silicon diode. (4)
- 8.5 Name TWO important pieces of information you can read on a data sheet. (2)
- 8.6 Explain the principle of operation of a zener diode. (2)
- A circuit consists of a 12 V DC supply, a diode and a load of 15 Ω .
Answer the questions that follow:
- 8.7 8.7.1 Calculate the maximum current for this diode. (3)
 - 8.7.2 Calculate the maximum voltage for this diode. (2)
- 8.8 Draw a fully labelled symbol diagram for a NPN transistor. (4)
- 8.9 Name TWO applications of a transistor. (2)
- 8.10 Name the THREE regions a transistor operates in. (3)
- 8.11 Explain TWO methods of switching an SCR on. (4)
- 8.12 Explain the principle of operation of a DIAC. (6)
- 8.13 Draw a fully labelled symbol of a DIAC. (4)
- 8.14 Name the advantage of a TRIAC compared to an SCR. (2)

[48]

QUESTION 9: SENSORS AND TRANSDUCERS

- 9.1 Describe the application of a proximity sensor. (2)
- 9.2 Explain the operation of a humidity sensor. (3)
- 9.3 Explain the purpose of a photodiode in an electric circuit. (3)
- 9.4 Name TWO types of thermistors. (2)
- 9.5 Define the term *transducer*. (2)

[12]**TOTAL: 200**

ELECTRICAL TECHNOLOGY FORMULA SHEET**WAVE FORMS**

Frequency

$$f = \frac{1}{T}$$

Maximum value

$$V_{MAX} = V_{RMS} \times 1,414 (V)$$

RMS Value

$$V_{RMS} = V_{MAX} \times 0.707$$

Average value

$$V_{ave} = V_{max} \times 0.637$$

POWER SUPPLIES

$$V_{ave} = V_{pk} - \frac{1}{2} V_{RIP P-P}$$

$$V_{OUT} = V_Z$$

$$V_O = V_Z - V_{BE}$$

$$I_L = I_E (\beta + 1) I_B$$

RLC CIRCUITS*Inductive reactance*

$$X_L = 2\pi fL$$

Capacitive reactance

$$X_C = \frac{1}{2\pi fC}$$

Impedence

$$Z = \sqrt{R^2 + (X_L - X_C)^2}$$

Power factor

$$\cos \theta = \frac{R}{Z}$$

$$\cos \theta = \frac{VR}{VZ}$$

AMPLIFIERS

$$V_{CE max} = V_{VCC}$$

$$V_{CC} = V_{CE} + I_C R_C$$

$$I_C = \beta I_B$$

$$A_V = \frac{\text{Output voltage}}{\text{input voltage}}$$

$$A_I = \frac{\text{output current}}{\text{input current}}$$

