

STAPLE



# basic education

Department:  
Basic Education  
REPUBLIC OF SOUTH AFRICA

**SENIOR CERTIFICATE/  
NATIONAL SENIOR CERTIFICATE**

**GRADE 12**

**ENGINEERING GRAPHICS AND DESIGN P1**

**NOVEMBER 2020**

**MARKS: 100**

**TIME: 3 hours**

**This question paper consists of 6 pages.**

Barcode label



## INSTRUCTIONS AND INFORMATION

1. This question paper consists of FOUR questions.
2. Answer ALL the questions.
3. ALL drawings are in first-angle orthographic projection, unless otherwise stated.
4. ALL drawings must be prepared using pencil and instruments, unless otherwise stated.
5. ALL answers must be drawn accurately and neatly.
6. ALL the questions must be answered on the QUESTION PAPER, as instructed.
7. ALL the pages, irrespective of whether the question was attempted or not, must be re-stapled in numerical sequence in the TOP LEFT-HAND CORNER ONLY.
8. Time management is essential in order to complete all the questions.
9. Print your examination number in the block provided on every page.
10. Any details or dimensions not given must be assumed in good proportion.

FOR OFFICIAL USE ONLY															
QUESTION	MARKS OBTAINED			1/2	SIGN	MODERATED			1/2	SIGN	RE-MARKING			1/2	SIGN
1															
2															
3															
4															
<b>TOTAL</b>															
	2	0	0			2	0	0			2	0	0		

FINAL CONVERTED MARK	CHECKED BY
100	

<b>COMPLETE THE FOLLOWING:</b>
CENTRE NUMBER
CENTRE NUMBER
EXAMINATION NUMBER
EXAMINATION NUMBER



CORNER HEIGHTS AND BOUNDARY LENGTHS OF STAND 2468 IN METRES			
A	357,5	AB	59,5
B	356,7	BC	23,45
C	356,3	CD	61,15
D	357,1	DA	37,5

**SYMBOL LEGEND:**

- DECIDUOUS TREES
- SHRUBBERY
- DRAIN FIELD

**NOTE:**

Contractors must verify all dimensions and levels on site before commencing work. Architects to be notified immediately of any discrepancies.

ARCHITECT'S SIGNATURE: .....

CLIENT'S SIGNATURE: .....

**ANSWER 20**

In the space below, draw, in neat freehand, the front view and top view of the SANS 10143 graphical symbol for a SINGLE SLAB or STALL TYPE URINAL.

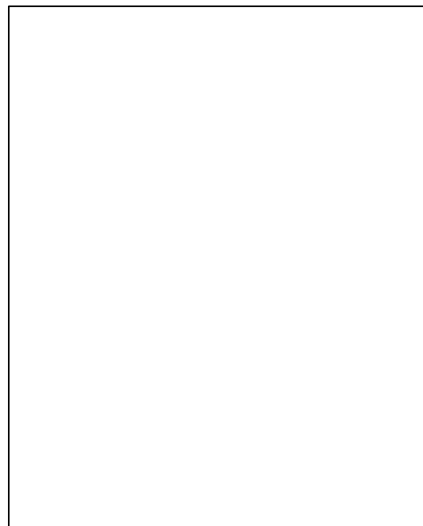

REVISION	DATE	DESCRIPTION
1	2019-07-08	ADD COLOUR FOR NEW WORK

**FUNKY DESIGNS**

52 Rex Street, George  
041 640 4321  
fd.architects@yahoo.com

PRINTED BY: TIME-PRINT      DATE OF PRINT: 2019-09-21

DRAWING TITLE: **SITE PLAN**

PROJECT: PROPOSED NEW FLATLET AND GARAGE FOR MR A BOBANI ON STAND 2463, BROWN STREET, GEORGE, 6529.

PROJECT NUMBER: FBBS-2019      DRAWING NUMBER: 1 OF 6

DATE: 2019-07-05      DRAWN: CALIB      CHECKED: ASHLEY      SCALE: 1 : 400

REFERENCE CODE: 422-2019

**QUESTION 1: ANALYTICAL (CIVIL)**

**Given:**

The site plan of an existing house and a proposed new flatlet and garage, a title panel and a table of questions. The drawing has not been prepared to the indicated scale.

**Instructions:**

Complete the table below by neatly answering the questions, which refer to the accompanying drawing, title panel and civil content. **[30]**

QUESTIONS		ANSWERS	
1	What is the reference code of the drawing?	1	
2	Who is the client?	1	
3	On what date was the drawing printed?	1	
4	How many signatures are required?	1	
5	How many stands border STAND 2463?	1	
6	What is the number of the electrical substation?	1	
7	What does the abbreviation IC stand for?	1	
8	What is the height of the precast concrete wall in metres?	1	
9	What is the abbreviation of the component that you will find at 1?	1	
10	What is the colour that must be added to new work, as indicated in the revision?	1	
11	What does the chain line at 2 indicate?	1	
12	Name the symbol at 3.	1	
13	Name the feature at 4.	1	
14	What is the fall of the new sewer line?	1	
15	Which elevation of the existing house faces the new flatlet?	2	
16	What is the total height of the retaining wall in metres?	2	
17	Determine the distance from boundary AD to the reference corner P on the proposed new flatlet in metres.	2	
18	In the space below (ANSWER 18), determine the total length of the precast concrete fence in metres.	3	
19	In the space below (ANSWER 19), determine the total area of the proposed new flatlet and garage in square metres. Round the answer off to TWO decimal places.	3	
20	In the space in the title panel (ANSWER 20), draw, in neat freehand, the front view and top view of the SANS 10143 graphical symbol for a SINGLE SLAB or STALL TYPE URINAL.	4	
<b>TOTAL</b>		<b>30</b>	

**ANSWER 18**  
Show ALL calculations.

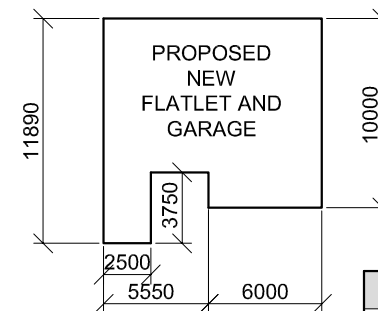

**ANSWER 19**  
Show ALL calculations.

EXAMINATION NUMBER	
EXAMINATION NUMBER	<b>2</b>

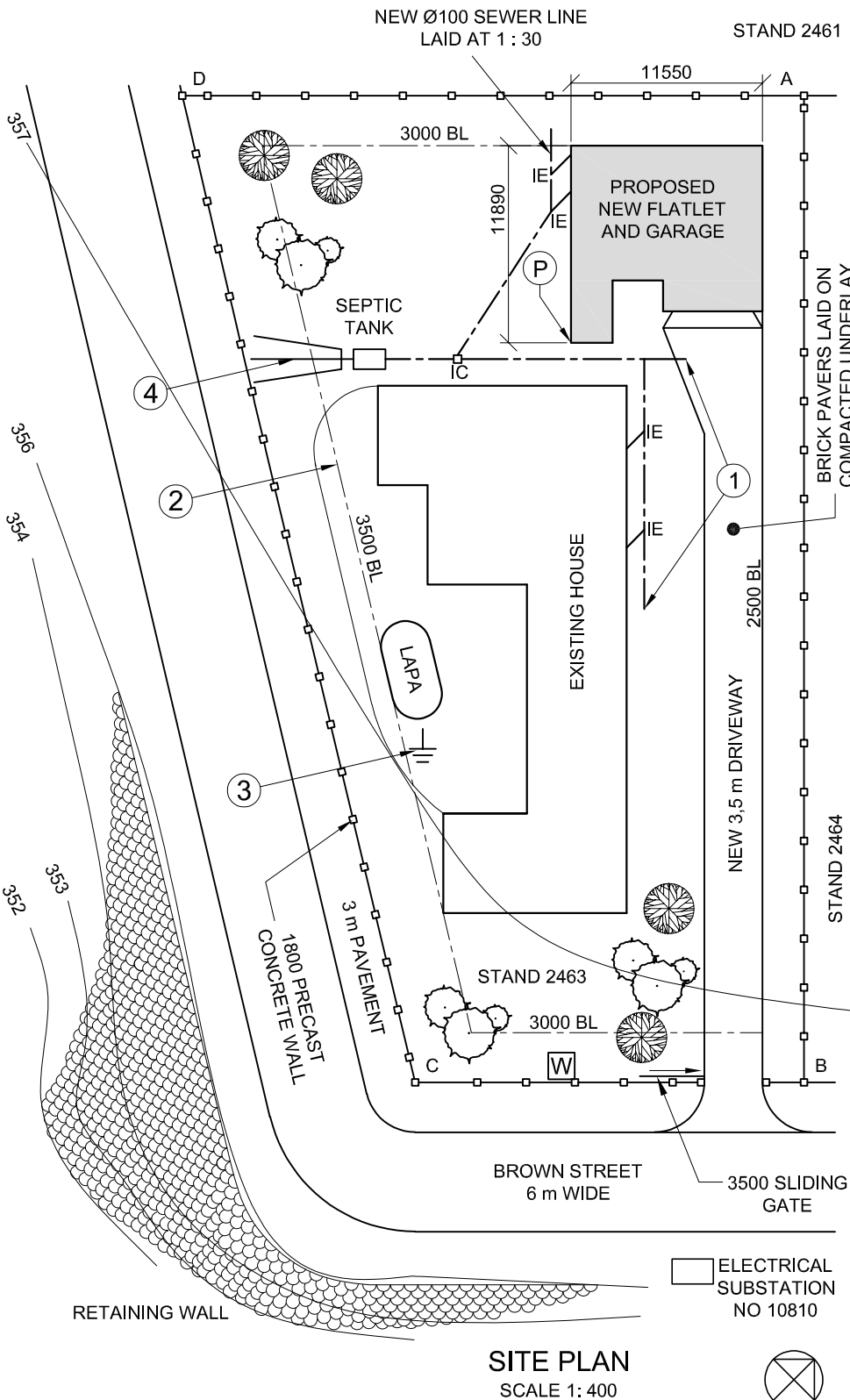

**SITE PLAN**  
SCALE 1: 400





**QUESTION 2: SOLID GEOMETRY**

**Given:**

- The front view and the top view of a right regular hexagonal pyramid and a right square pyramid
- Cutting plane S-S

**Specifications:**

- The two solids do not touch
- Both solids are cut by cutting plane S-S

**Instructions:**

Draw, to scale 1 : 1, the following views of the TWO solids:

- 2.1 The given front view
- 2.2 A sectional top view
- 2.3 A sectional right view
- 2.4 The true shape of the cut surface of the hexagonal pyramid

- Planning is essential.
- Show ALL construction.
- Show ALL hidden detail.

**[38]**

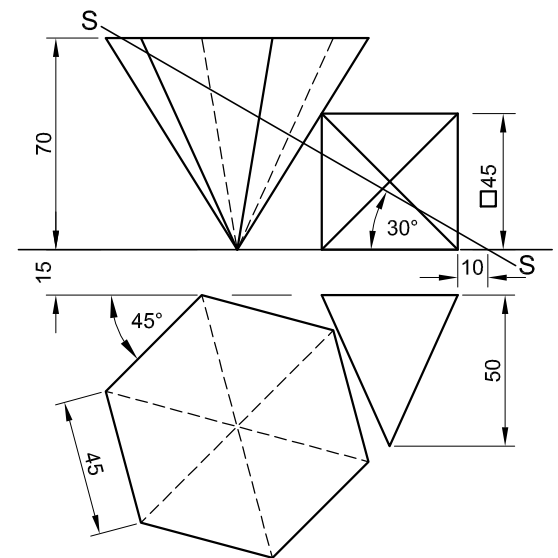

ASSESSMENT CRITERIA			
1	FRONT VIEW	7½	
2	SECTIONAL TOP VIEW + CONSTRUCTION	13½	
3	SECTIONAL RIGHT VIEW	11½	
4	TRUE SHAPE	5½	
PENALTIES (-)			
<b>TOTAL</b>		<b>38</b>	
EXAMINATION NUMBER			
EXAMINATION NUMBER			
EXAMINATION NUMBER			<b>3</b>





**QUESTION 3: PERSPECTIVE**

**Given:**

Three views of a building and the information needed to draw a two-point perspective drawing

PP – Picture plane

HL – Horizon line

GL – Ground line

SP – Station point

**Instructions:**

Complete the perspective drawing.

- Align the drawing sheet with the ground line (GL).
- Determine and label the vanishing points.
- Show ALL construction.
- Show internal lines seen through the hexagonal and arc openings.
- NO hidden detail is required. [38]

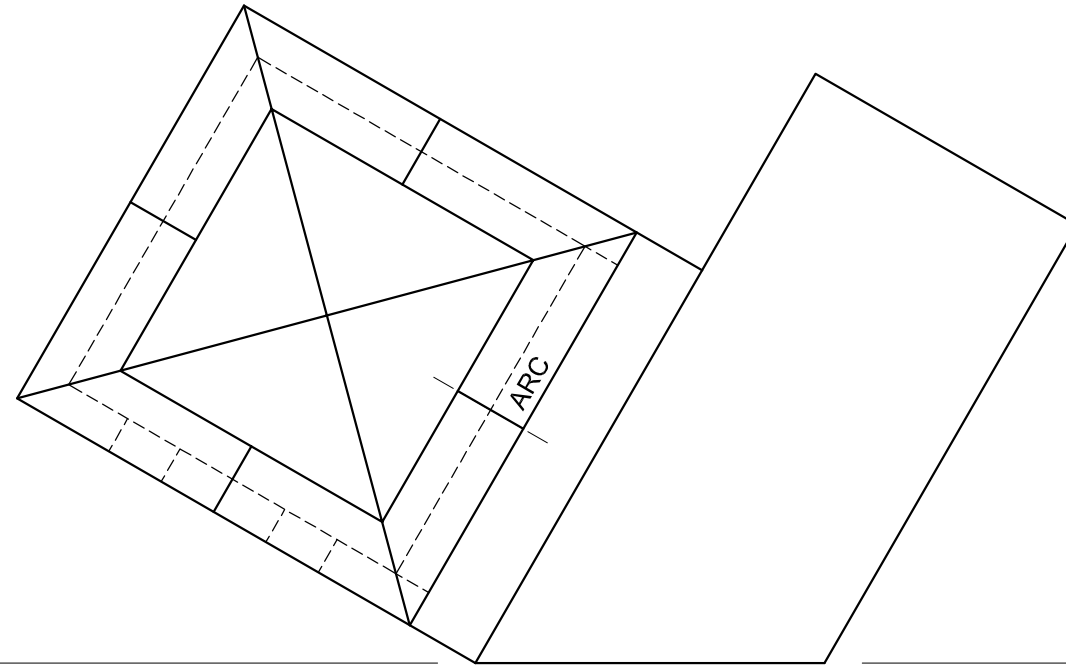

ASSESSMENT CRITERIA				
1	CONSTRUCTION	6		
2	WALLS	10½		
3	HEXAGONAL OPENING	5½		
4	ROOF	9½		
5	ARC	6½		
PENALTIES (-)				
<b>TOTAL</b>		<b>38</b>		

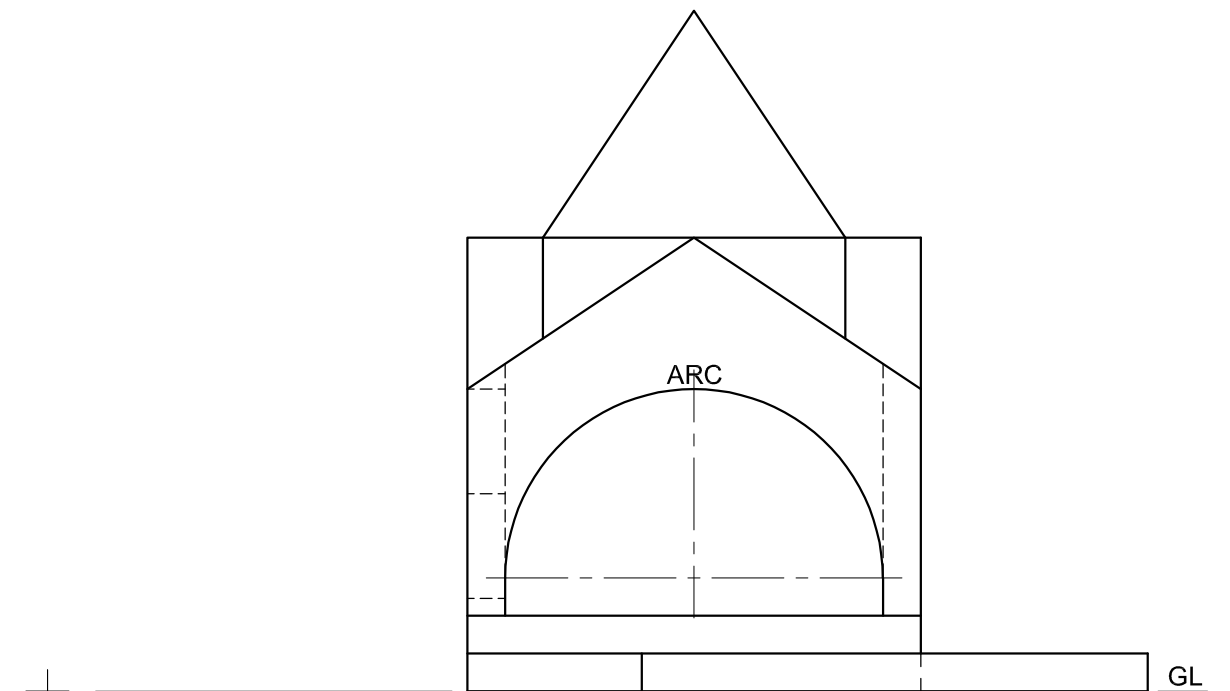
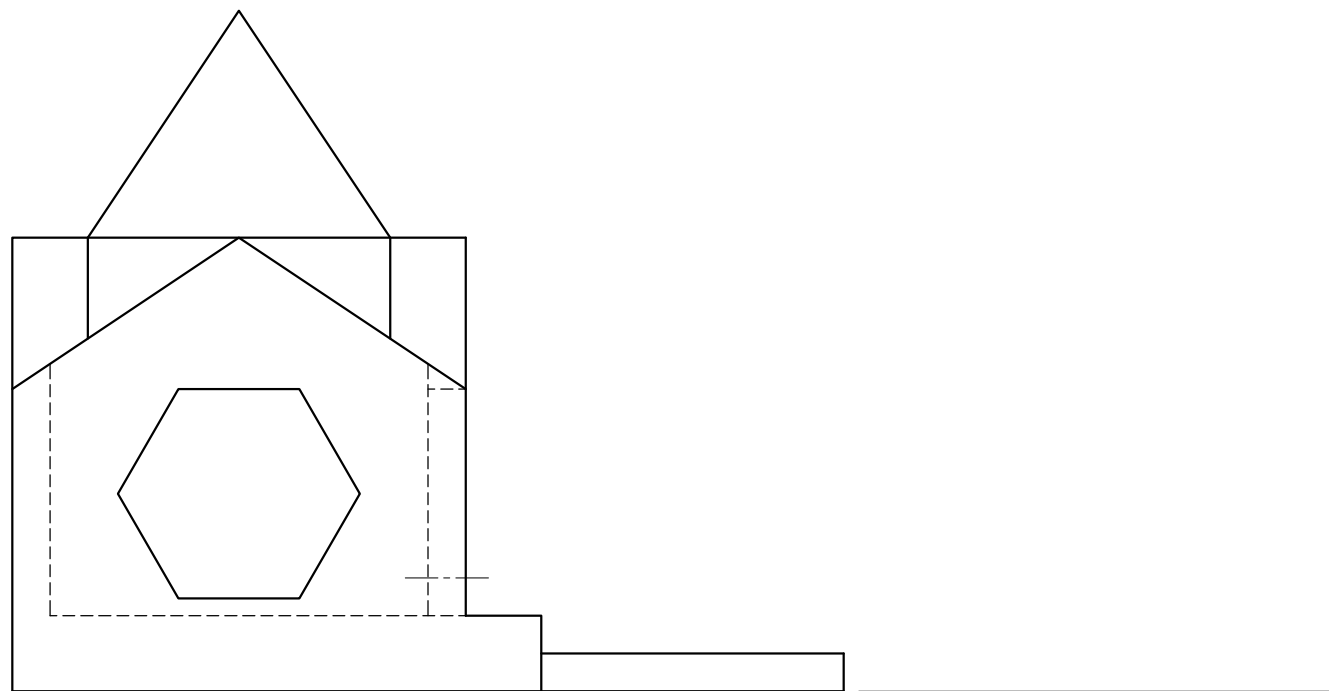

EXAMINATION NUMBER	
EXAMINATION NUMBER	4



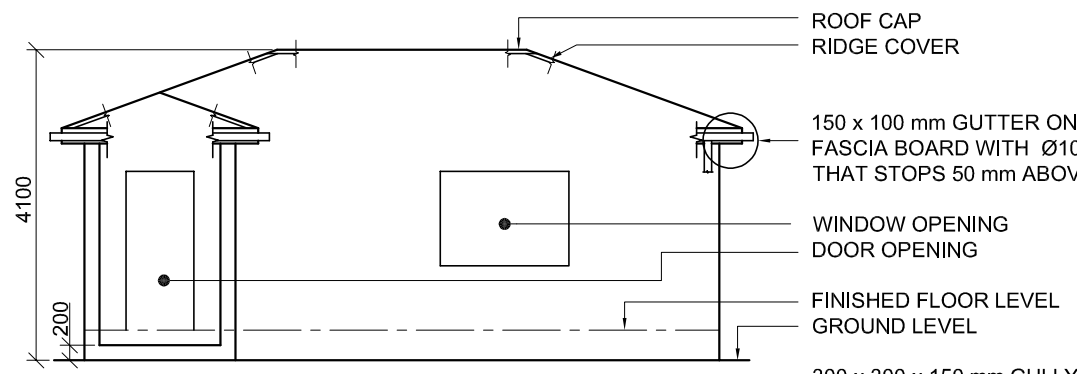

INCOMPLETE SOUTH ELEVATION

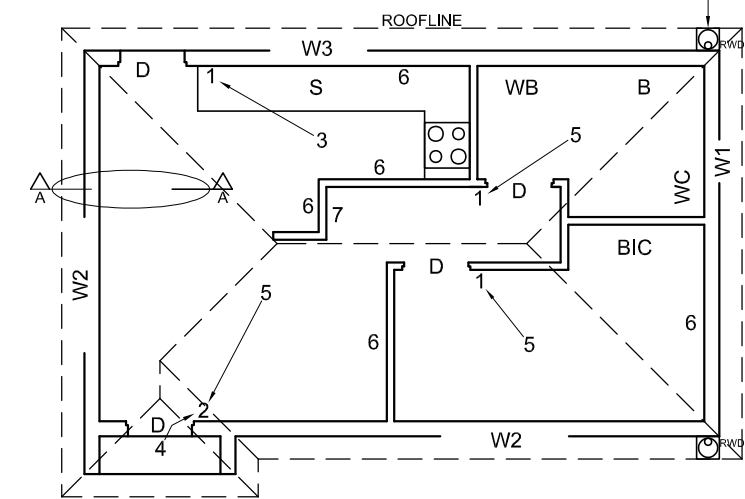

INCOMPLETE FLOOR PLAN

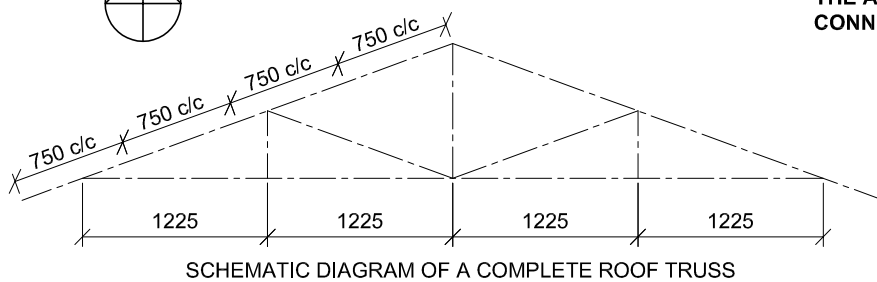

SCHEMATIC DIAGRAM OF A COMPLETE ROOF TRUSS

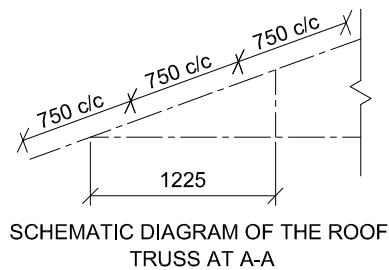

SCHEMATIC DIAGRAM OF THE ROOF TRUSS AT A-A

**ROOF NOTES:**

- 20° ROOF PITCH
- 114 x 40 mm ROOF TRUSS ON 114 x 40 mm WALL PLATES
- 300 mm ROOF OVERHANG TO END OF ROOF TRUSS
- 20 mm FIBRE CEMENT ROOF SHEETING ON 75 x 50 mm PURLINS @ 750 mm c/c
- 200 x 20 mm FASCIA BOARDS WITH 150 x 100 mm GUTTERS ON ALL SIDES
- 10 mm CEILING BOARD ON 40 x 40 mm BRANDING STRIPS @ 600 mm c/c

- ROOF CAP RIDGE COVER
- 150 x 100 mm GUTTER ON 200 x 20 mm FASCIA BOARD WITH Ø100 mm RWDP THAT STOPS 50 mm ABOVE THE GULLY
- WINDOW OPENING
- DOOR OPENING
- FINISHED FLOOR LEVEL
- GROUND LEVEL
- 300 x 300 x 150 mm GULLY

**FEATURES**

- D DOOR
- W1 TO W3 WINDOWS

**FIXTURES**

- WC TOILET
- WB WASHBASIN
- B BATH
- S SINK
- BIC BUILT-IN CUPBOARD

**ELECTRICAL FITTINGS**

- ONE-WAY SWITCH - SINGLE-POLE
- ONE-WAY SWITCH - DOUBLE-POLE
- FLUORESCENT LIGHT 2 x 40 W
- WALL-MOUNTED LIGHT
- CEILING LIGHT
- SWITCHED SOCKET OUTLET
- DISTRIBUTION BOARD

**NOTE:**

THE ARROW SHOWS THE LIGHT CONNECTION TO THE SWITCH.

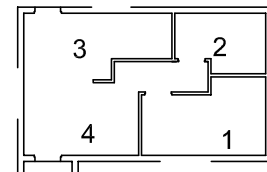

**ROOM DESIGNATIONS**

- FLOOR FINISHES**
- 1 BEDROOM: CARPET
  - 2 BATHROOM: TILE
  - 3 KITCHEN: WOOD
  - 4 LOUNGE: WOOD

**ELECTRICAL SYMBOLS**

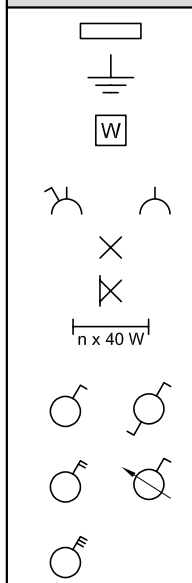

**WINDOW NOTES:**

- A = OPENING SIDE
- B = HINGED SIDE
- C = FIXED PANEL
- ALL FRAMES = 50 mm
- 150 x 20 mm FIBRE CEMENT SILL UNDER ALL WINDOWS

**DOOR AND WINDOW SCHEDULE**

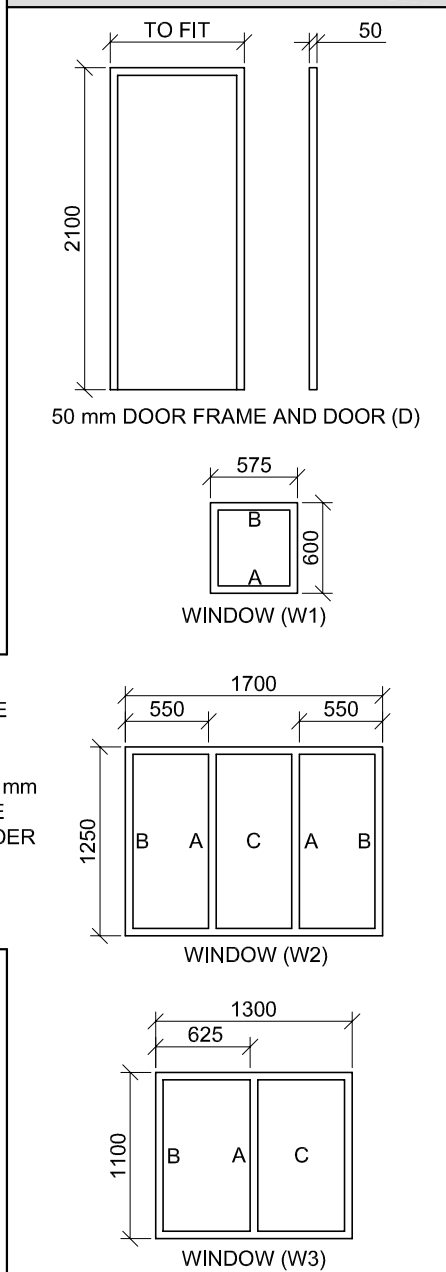

ROOF COMPONENTS	
	114 x 40 mm WALL PLATE
	ROOF CAP AND RIDGE COVER
	150 x 100 mm GUTTER
	200 x 20 mm FASCIA BOARD

**FIXTURES**

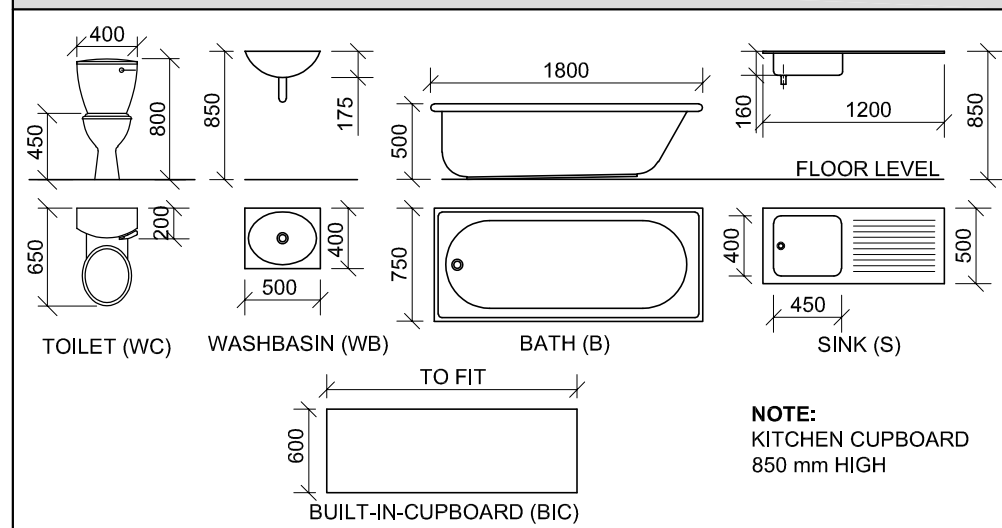

**QUESTION 4: CIVIL DRAWING**

**Given:**

- The incomplete south elevation of a **new house**, showing the walls, the door and window openings, the roof and labels
- The incomplete floor plan showing the walls, positions of the doors, windows, fixtures and the electrical layout
- Schematic diagrams of roof trusses and roof notes
- The incomplete foundation and external wall detail
- Room designations and floor finishes
- A table of electrical symbols
- A table of roof components
- A table of fixtures
- A door and window schedule
- The incomplete floor plan of the **new house**, drawn to scale 1 : 50, and corner 'B' of the foundation and the break line for the detailed section, drawn to scale 1 : 20, on page 6

**Instructions:**

Answer this question on page 6.

4.1 Using the given incomplete floor plan, draw, in first-angle orthographic projection and to scale 1 : 50, the following views of the **new house**:

**4.1.1 THE COMPLETE FLOOR PLAN**

**Add the following features to the drawing:**

- ALL doors and windows
- The fixtures as indicated by the abbreviations
- ALL electrical fittings as indicated by the numbers
- ALL hatching detail

**4.1.2 THE COMPLETE SOUTH ELEVATION**

**Show the following features on the drawing:**

- The outside walls, step, door and window detail
- The roof detail, including the fascia boards, gutters and rainwater down-pipe
- The finished floor level

4.2 Using corner 'B' of the foundation and the break line on page 6, draw, to scale 1 : 20, a **DETAILED SECTION** on cutting plane A-A of the area in the ellipse shown on the incomplete floor plan.

**Show the following features on the drawing:**

- The foundation and external wall detail
- The roof detail, including the fascia board and gutter
- The door frame and kitchen cupboard north of (above) the ellipse
- ALL hatching detail. ONLY the substructure hatching may be drawn in neat freehand.

**Label the following:**

- The south elevation
- The room designations and floor finishes
- Ground level, finished floor level, damp-proof course and built-in cupboard (use the correct abbreviations and show it on ALL the relevant views)

**NOTE:**

ALL drawings must comply with the **guidelines** and **graphical symbols** as contained in the **SANS 10143**. [94]



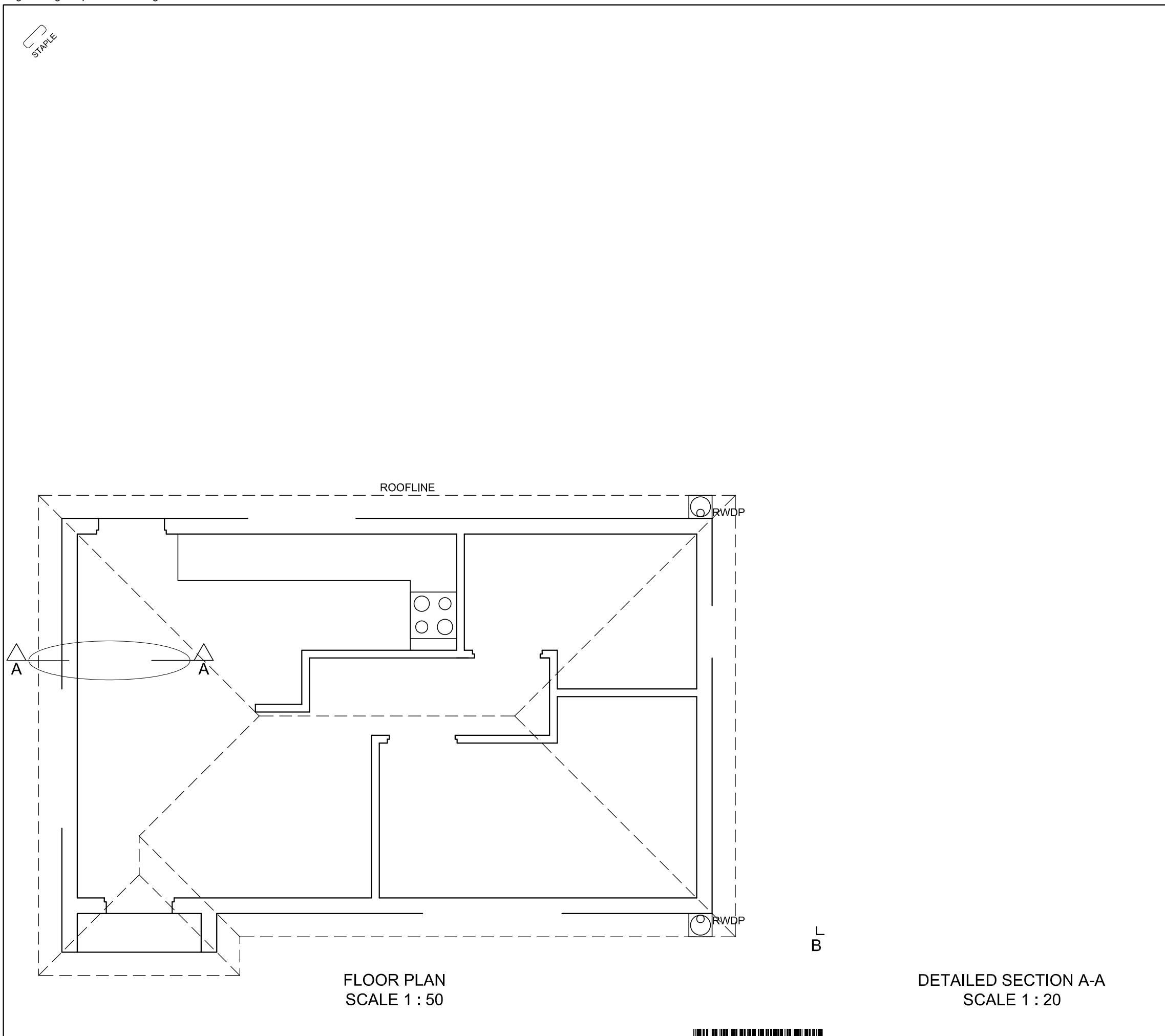

MARK ALLOCATION FOR ROOF SECTION (4.2)	
A	
B	
C	
D	
E	
F	
G	
H	
I	
<b>TOTAL</b>	

FOR OFFICIAL USE ONLY	
INCORRECT SCALE	
NON-ALIGNMENT OF VIEWS	
VIEW(S) ROTATED	
SECTION VIEWED INCORRECTLY	
INCORRECT LETTERING	
<b>TOTAL</b>	

ASSESSMENT CRITERIA					
FLOOR PLAN					
		POSSIBLE	OBTAINED	SIGN	MODERATED
1	DOORS + WINDOWS	12			
2	ELECTRICAL	10			
3	FIXTURES	9½			
4	HATCHING	3			
5	LABELS	4½			
<b>SUBTOTAL</b>		<b>39</b>			
SOUTH ELEVATION					
1	ROOF + RWDP	10½			
2	WALLS + FFL	5½			
3	DOOR + WINDOW	7½			
4	LABELS	1½			
<b>SUBTOTAL</b>		<b>25</b>			
DETAILED SECTION					
1	ROOF DETAIL	13			
2	WALL	8			
3	DOOR + CUPBOARD	4			
4	HATCHING	4			
5	LABELS	1			
<b>SUBTOTAL</b>		<b>30</b>			
<b>TOTAL</b>		<b>94</b>			
PENALTIES (-)					
<b>GRAND TOTAL</b>					
EXAMINATION NUMBER					
EXAMINATION NUMBER					
<b>6</b>					

DETAILED SECTION A-A  
SCALE 1 : 20

FLOOR PLAN  
SCALE 1 : 50

